





Practical Guide

Physics
for 'O' Level
**Practical
Assessment**

Sharon Kwok

 **HODDER
EDUCATION**
AN HACHETTE SINGAPORE COMPANY

Contents

	Preface	iii
Theme 1	Measurement	1
	Experiment 1.1	8
	Experiment 1.2 	13
Theme 2	Mechanics	18
	Experiment 2.1 	22
	Experiment 2.2	27
Theme 3	Thermal physics	32
	Experiment 3.1 	36
	Experiment 3.2	41
Theme 4	Light	45
	Experiment 4.1	50
	Experiment 4.2 	55
Theme 5	Electricity	60
	Experiment 5.1	66
	Experiment 5.2 	72
	Practical checklists	78
	Formulas and glossary	80
	Experiment sample results	84
	Materials preparation list	88
	Answers	99
	Index	146

Measurement

Measurement

Measurement of physical quantities is important in Physics as the measured values and units are used in calculations. Accurate measurements give accurate results after calculations.

Measurement errors reduce the accuracy of measurements and results. Precautions should be taken to minimize errors as much as possible.

Repeating experiments and calculating average values improves the reliability of results.

Length

Apparatus	Range of values	Precision	Special uses
Measuring tape	More than 1 m	0.5 mm	Circumference
Ruler (half metre rule or metre rule)	1 mm to 1 m	0.5 mm	
Analogue Vernier callipers	0.1 mm to 300 mm	0.1 mm	External diameter Internal diameter Depth
Analogue Micrometer screw gauge	0.01 mm to 25 mm	0.01 mm	External diameter

Mass

Mass can be measured directly using an electronic balance. An electronic balance measures mass in grams to a precision of 2 decimal places (d.p.) or 3 d.p.

Mass can also be measured directly using a beam balance. This involves balancing the unknown mass with known masses along a bar or rod which is balanced in the middle. The unknown mass is placed at one end of the bar. Known masses are added to the opposite end of the bar until the bar becomes horizontal and is balanced. The unknown mass would be equal to the sum of the known masses.

Volume

Liquid

Volume can be measured directly using a measuring cylinder. A measuring cylinder measures volume to a precision of 0.1 cm^3 to 1 cm^3 depending on the size (e.g. 10.0 cm^3 , 50.0 cm^3 or 100.0 cm^3) of the measuring cylinder.

Regular-shaped solid

Measure the length, width, height or diameter of the solid. Calculate the volume of the solid using the appropriate mathematical formula for the cube, cuboid, cylinder, sphere or prism.

$$\text{Volume of cube} = \text{length}^3$$

$$\text{Volume of cuboid} = \text{length} \times \text{width} \times \text{height}$$

$$\text{Volume of cylinder} = \pi \times \left(\frac{\text{diameter}}{2}\right)^2 \times \text{height}$$

$$\text{Volume of sphere} = \frac{4}{3} \times \pi \times \left(\frac{\text{diameter}}{2}\right)^3$$

$$\text{Volume of prism} = \text{cross-sectional area} \times \text{height}$$

Irregular-shaped solid

Volume can be measured indirectly using displacement of water. A displacement can or measuring cylinder can be used. Measuring cylinders are usually available but not displacement cans.

Pour a certain volume of water into a measuring cylinder. Measure the initial volume of water. Place the solid into the water. Ensure that the solid is completely covered by the water. Measure the total volume of solid and water. The volume of the solid is equal to the difference in the two liquid volumes.

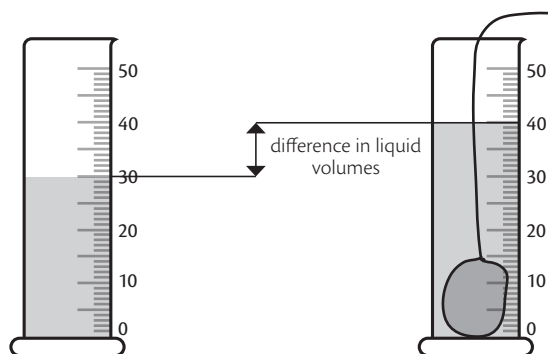

Time

Time can be measured directly in seconds using a stopwatch. A stopwatch measures time to a precision of 1 d.p. or 2 d.p. However, stopwatch readings are rounded off to the nearest second to take into account the effect of human reaction time.

A pendulum is an object which moves in a repetitive manner (oscillates) over time by itself. The period is the time taken for 1 complete oscillation. Pendulums were used to measure time as the period of a pendulum is fixed. Only the length of a pendulum affects its period.

Density

$$\text{Density} = \frac{\text{mass}}{\text{volume}}$$

Density is the mass per unit volume of a material. Different materials have different densities.

Density determines whether a substance will float or sink in a liquid or gas. A substance that has a lower density floats and rises upwards. A substance with a higher density than the liquid or gas will sink and move downwards. A substance of the same density as the liquid or gas will not float or sink. It will be suspended in the liquid or gas.

Density is affected by temperature. As temperature increases, density decreases.

Angles

Angles are constructed and measured in degrees (from 0° to 180°) using protractors.

Measurement experiments

Experiments on length commonly involve the use of rulers. The use of a Vernier calliper or a micrometer screw gauge is less common.

Experiments on mass may involve balancing the object on a rod using the principle of moments.

Experiments on volume may involve measurement of length or displacement of water.

Experiments on pendulums may involve any object which moves in a repeated motion. The object may be suspended by a string, wire or spring.

Practical tips

Parallax error

Parallax error should be avoided by taking readings at eye level.

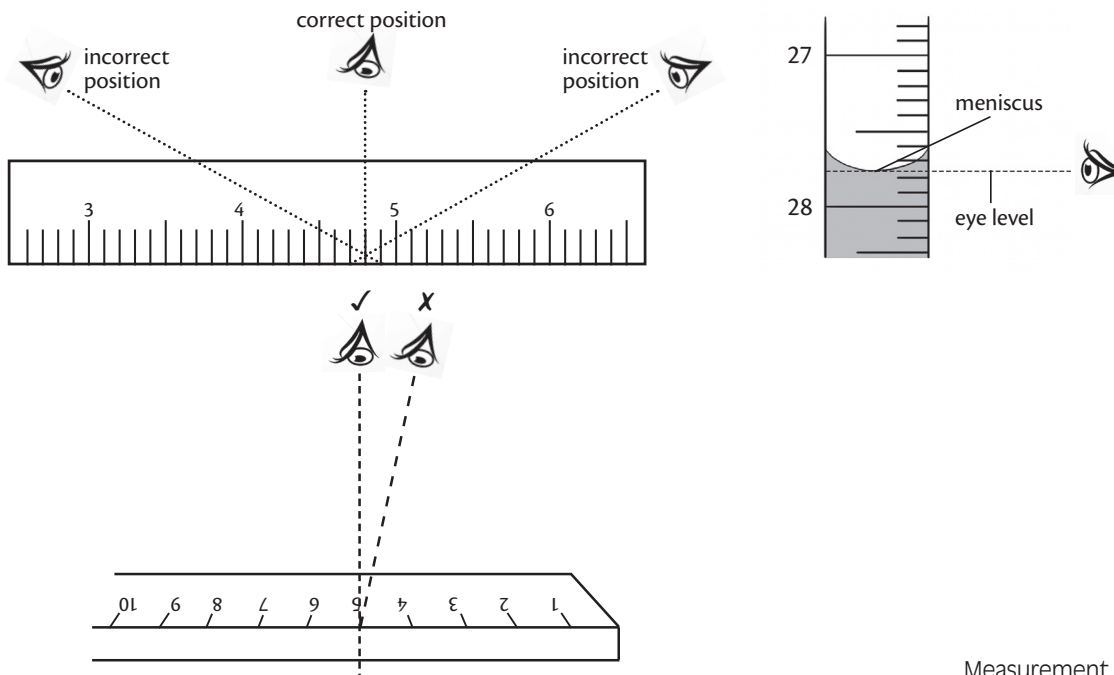

Zero errors

A Vernier calliper and a micrometer screw gauge may have zero errors. Zero errors can be detected when the jaws are closed and the zero marks of the two scales do not coincide with each other.

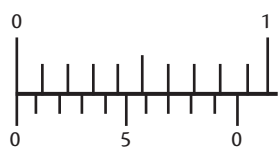

Vernier calliper without a zero error

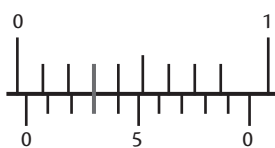

Vernier calliper with a positive zero error

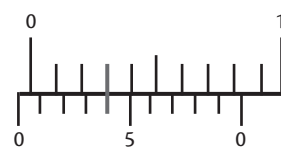

Vernier calliper with a negative zero error

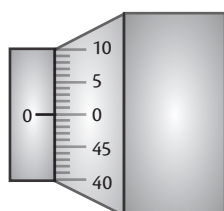

micrometer screw gauge without a zero error

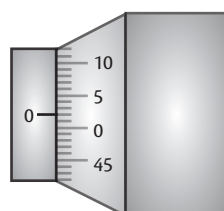

micrometer screw gauge with a positive zero error

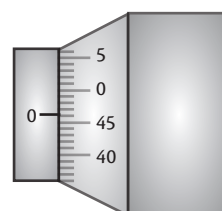

micrometer screw gauge with a negative zero error

Use of set squares

Set squares can be used to ensure accurate measurement of diameter if Vernier callipers (in cm) or a micrometer screw gauge (in mm) are absent or not suitable.

Place one set square touching each end of the solid. Place a ruler along the other edge of the set squares. The diameter of the solid is equal to the length between the two set squares.

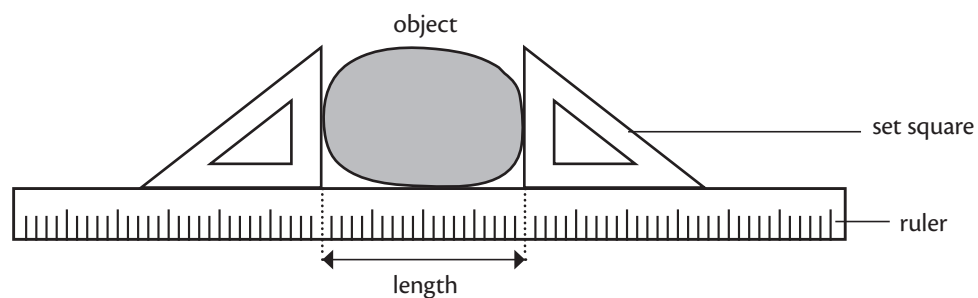

Principle of moments

Mass can be measured indirectly using the principle of moments (turning effect of a force). Masses are placed along a rod until the rod is balanced (horizontal and stationary). The unknown mass would be determined through calculation of moments.

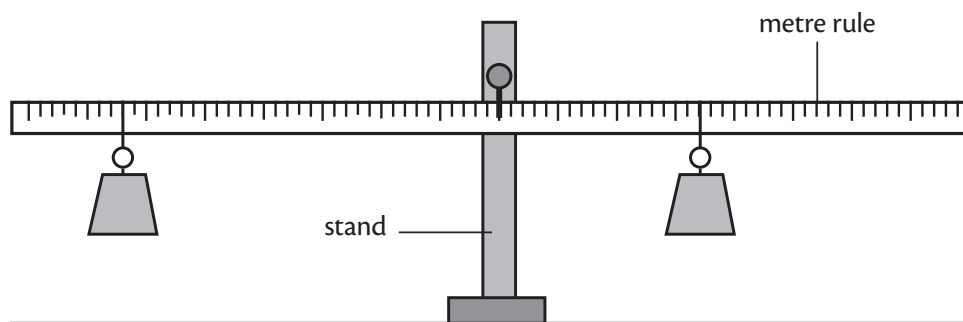

Moment = force \times perpendicular distance from pivot (fixed point)

Principle of moments: sum of clockwise moments = sum of anticlockwise moments about the same pivot

Mass of liquid

Measure the mass of an empty container. Pour the liquid into the container. Measure the mass of the container with liquid. The difference in mass is the mass of the liquid.

Time measurements

Measurement of time using a stopwatch may be inaccurate due to human reaction time. Accuracy of measurements can be improved by using automatic sensors and data loggers.

Pendulum

Displace the pendulum bob slightly to one side (small angle of less than 10°). Check that the string is straight and taut. Release the pendulum bob gently by moving your fingers further apart. Do not push the pendulum bob. Start timing only after a few steady oscillations (same path, no wobbling). If the oscillations are not steady, stop the pendulum and restart the oscillations.

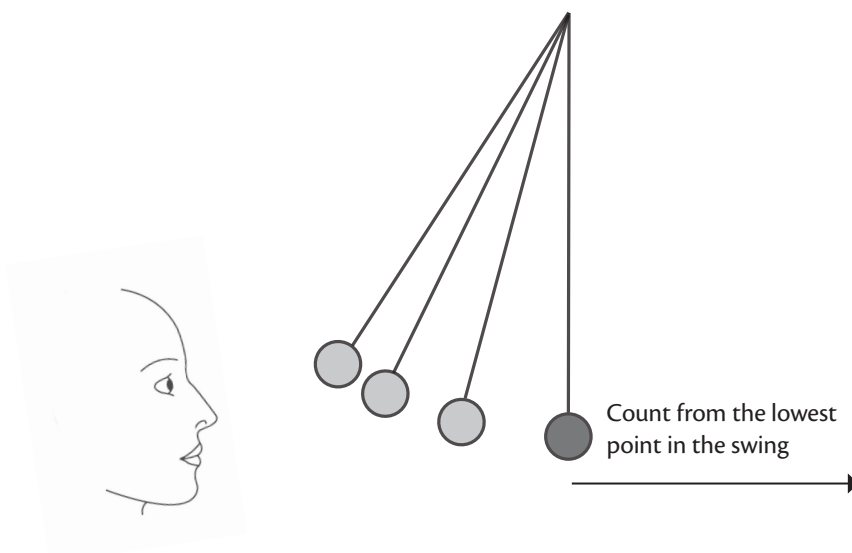
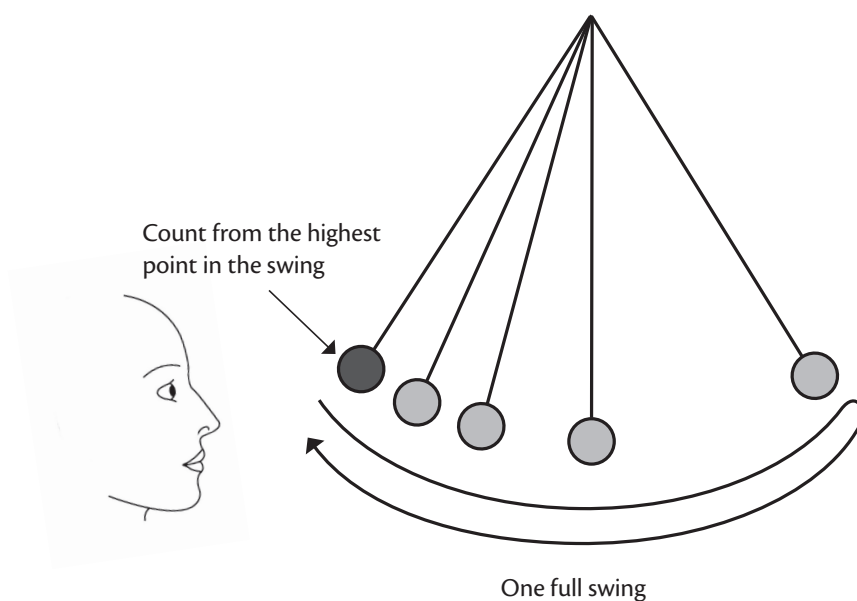
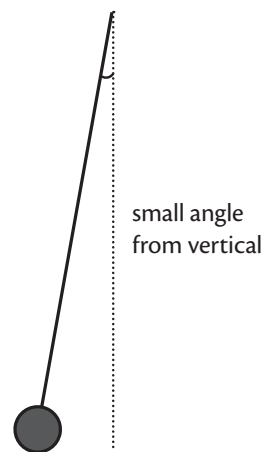

Planning

- Identify the independent variable (the variable you are changing at regular intervals) as determined by the aim.
- Suggest a minimum of five different values of the independent variable with regular intervals: e.g. 20°C, 30°C, 40°C, 50°C, 60°C. Describe briefly how the independent variable will be changed.
- Identify the dependent variable (the variable you want to measure) as determined by the aim.
- Suggest how to measure the dependent variable: e.g. measure volume of gas, measure mass, etc.
- State at least two fixed or controlled variables which can affect the results of the experiment. Describe how these controlled variables will be kept constant.
- Draw the diagrammatic set up needed or describe any modifications to the original set up which should be made.
- Write the apparatus used to make each measurement. Apparatus used in the main experiment may be used.
- The steps and details depend on the aim of the experiment. Steps from the main experiment may be used with modifications.
- Repeat the experiment and calculate the average results for reliability.
- State the expected results if the question requires you to do so.

Key marking points for planning

- Appropriate variables identified: independent, dependent and fixed or controlled variables
- Diagram or description of the set up needed
- Stepwise procedures of the experiment
- Expected results (if required)

Sample planning questions

1. Plan an experiment to determine the density of an irregular-shaped solid.
2. Plan an investigation to determine the effect of angle of displacement on the period of a pendulum.



Experiment 1.1

In this experiment, you will investigate the period of a pendulum.

You are provided with:

- A cube on a string
- A retort stand with clamp and split cork
- A metre rule
- A stopwatch

Set up the apparatus as shown in the diagram, with the distance **D**, between the point of support to the top of the bench, approximately 50 cm.

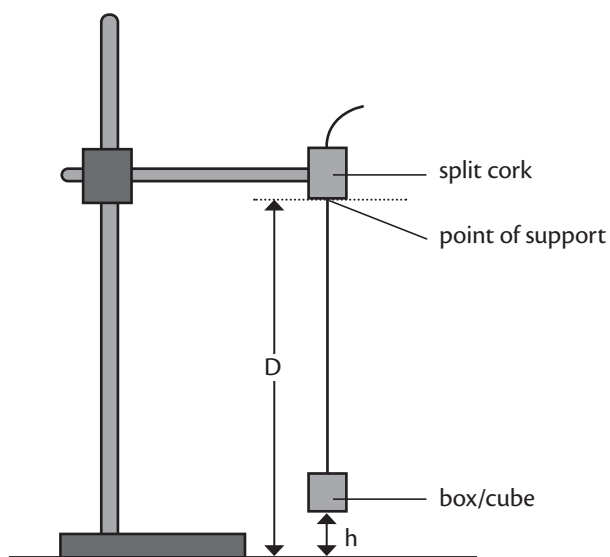

- (a) Measure **D**. [1]

D = _____

- (b) Adjust the length of the string until the height of the centre of the cube above the bench **h** is 15.0 cm. Displace the cube slightly to the side and release it so that it swings freely. Record the time taken for 20 oscillations **t**. [1]

t = _____

(c) Suggest how h can be measured more accurately. You may use additional apparatus. [1]

(d) Repeat with $h = 20.0$ cm, 25.0 cm, 30.0 cm, 40.0 cm. Record your results for h and t in a suitable table. Include your value from (b). [4]

(e) Calculate the period T and T^2 for each value of h and add these into your table. [2]

Answers

Experiment 1.1

In this experiment, you will investigate the period of a pendulum.

You are provided with:

- A cube on a string
- A retort stand with clamp and split cork
- A metre rule
- A stopwatch

Set up the apparatus as shown in the diagram, with the distance D , between the point of support to the top of the bench, approximately 50 cm.

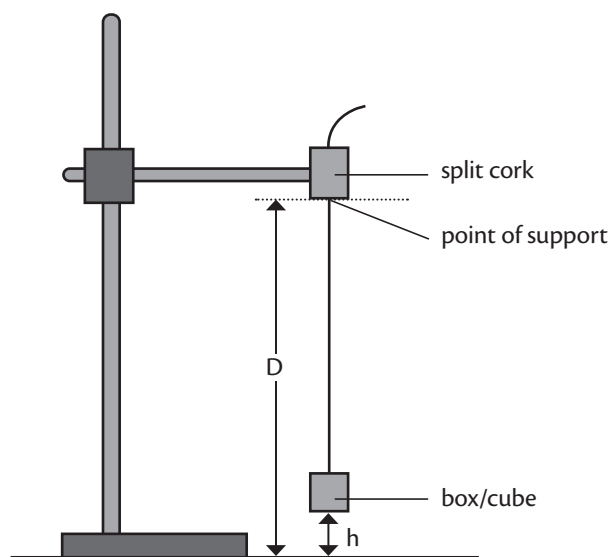

Skill Tip

Check that the metre rule is placed perpendicular to the bench for accurate measurement.

- (a) Measure D . [1]

$$D = 0.500 \text{ m (} 0.495 \text{ m - } 0.505 \text{ m)}$$

- (b) Adjust the length of the string until the height of the centre of the cube above the bench h is 15.0 cm. Displace the cube slightly to the side and release it so that it swings freely. Record the time taken for 20 oscillations t . [1]

$$t = 22.7 \text{ s (} 22.0 \text{ s - } 23.0 \text{ s)}$$

Skill Tip

Pull the cube a small angle (less than 10 degrees) away from the vertical. Check that the string is straight and taut.

Do not push the cube.

Start timing when the oscillations are regular and steady (following same path without wobbling).

- (c) Suggest how h can be measured more accurately. You may use additional apparatus. [1]

Use a set square to check that the metre rule is perpendicular to the bench before measuring h .

Draw a line around the middle of the cube and measure h from the line to the bench.

Attach a pointer to the middle of the cube and measure h from the pointer to the bench.

- (d) Repeat with $h = 20.0$ cm, 25.0 cm, 30.0 cm, 40.0 cm. Record your results for h and t in a suitable table. Include your value from (b). [4]

$h/$ m	$t/$ s	$T/$ s	$T^2/$ s ²
0.150	22.7 (22.0-23.0)	1.13 (1.10-1.15)	1.29 (1.21-1.32)
0.200	20.9 (20.0-21.0)	1.05 (1.00-1.05)	1.09 (1.00-1.10)
0.250	18.8 (18.0-19.0)	0.940 (0.900-0.950)	0.884 (0.810-0.903)
0.300	16.5 (16.0-17.0)	0.825 (0.800-0.850)	0.681 (0.640-0.723)
0.400	10.7 (10.0-11.0)	0.535 (0.250-0.550)	0.286 (0.0625-0.303)

- (e) Calculate the period T and T^2 for each value of h and add these into your table. [2]
- (f) Using the grid provided, plot a graph of T^2 against h . Start your axes from the origin (0, 0). Draw a straight line of best fit. [4]



Marking

S (scale) [1]: multiples of 2, 5 or 10, occupy more than $\frac{2}{3}$ of the grid.
 L (line) [1]: best fit line.
 A (axis) [1]: correctly labelled with relevant units.
 P (plot) [1]: points accurately plotted to half of smallest square.



Thought Process

Main difficulty/ inaccuracy in measuring h accurately is because the pendulum bob is spherical/ round.



Marking

Accept any plausible alternative.

Answering Skill

Readings should be recorded in SI units.



Marking

Headings with correct units [1]
 Values within range [1]
 5 paired values of h and t [1]
 Correct number of d.p. [1]



Marking

All values of T calculated correctly [1]
 All values of T^2 calculated correctly [1]



Thought Process

Is the relationship a direct proportion? For direct proportion, the graph should be a straight line passing through the origin (0, 0).

Answering Skill

All plotted points may not lie on the line. There should be plotted points alternating above and below the line, at approximately equal distances from the line.



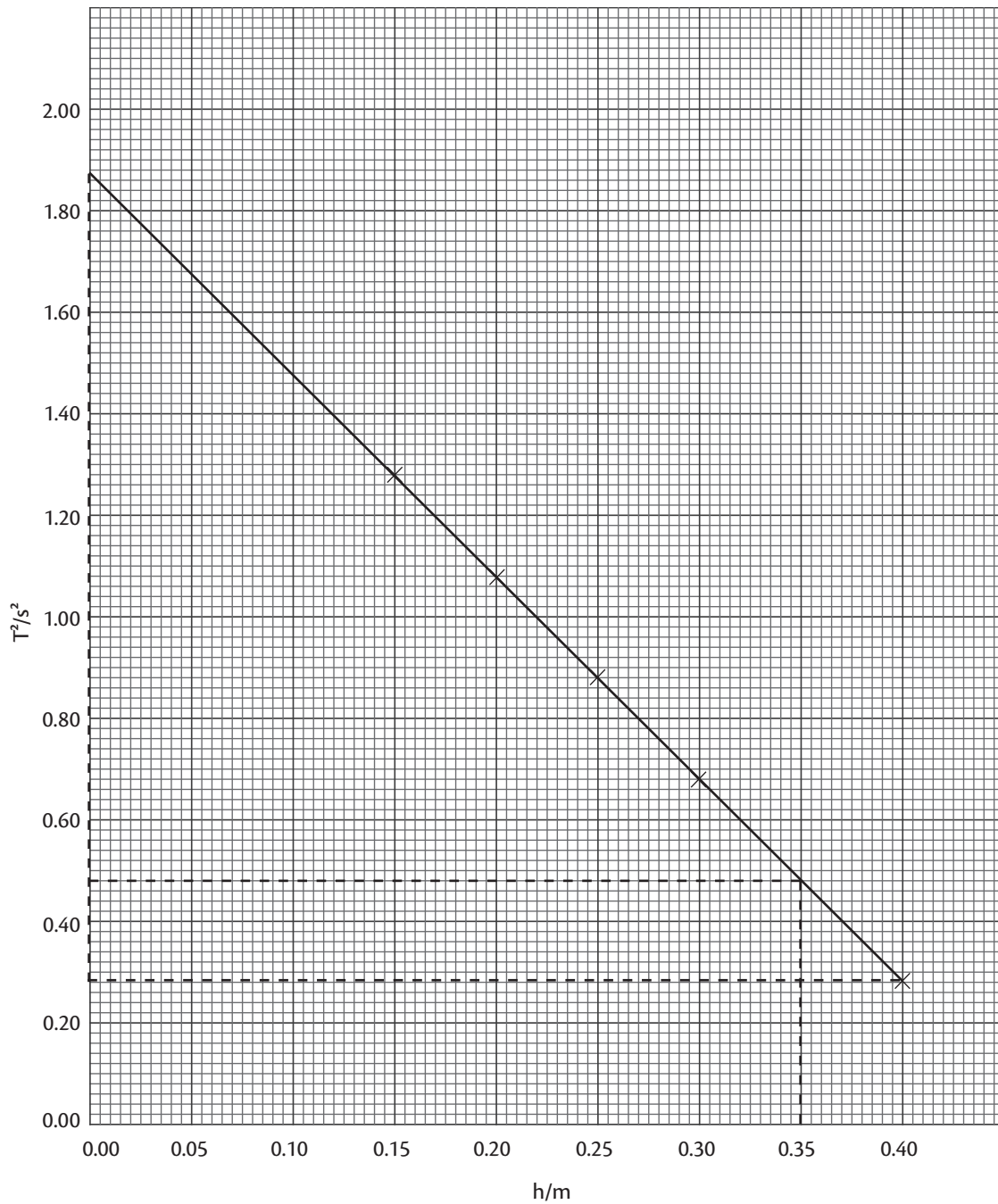

 **Marking**
Ignore anomalous results/
data.

- (g) From your graph, determine T when $h = 35.0$ cm. [2]

$$T^2 = 0.48 \text{ s}^2 \text{ (} 0.45 \text{ s}^2 \text{ -} 0.50 \text{ s}^2 \text{)}$$

$$T = \sqrt{0.48} = 0.693 \text{ s (} 0.671 \text{ s -} 0.707 \text{ s)}$$

- (h) Using your graph, state the value of the y-intercept c . [1]

$$c = 1.89 \text{ s}^2 \text{ (} 1.8 \text{ s}^2 \text{ -} 2.0 \text{ s}^2 \text{)}$$

- (i) Determine the gradient m of your line. [1]

$$m = \frac{0.286 - 1.89}{0.400} = -4.01 \text{ s}^2/\text{m (} -3.50 \text{ s}^2/\text{m -} -4.50 \text{ s}^2/\text{m)}$$

- (j) It is suggested that D is related to c and m by the relationship

$$D = -\frac{c}{m}.$$

Use this equation to calculate D . [1]

$$D = \frac{-1.89}{-4.01} = 0.471 \text{ m (} 0.400 \text{ m -} 0.571 \text{ m)}$$

- (k) Suggest 2 reasons why the actual value of D is different from the value calculated in (j). [2]

Actual value of D may not be accurate because of difficulty in measuring to point of contact.

Actual value of D may not be accurate because metre rule might not have been perpendicular to the bench.

Values of h may not be accurate because of inaccuracy in measuring to centre of cube.

Values of t may not be accurate due to human reaction time.



Thought Process

Find T^2 from the graph, then calculate T .

Answering Skill

Draw straight lines on the graph to show how you obtain the correct value of T^2 .



Answering Skill

How to calculate gradient?



Marking

Any 2 reasons [2]

1 reason [1]

Accept any plausible measurement/ method errors

Do not accept inaccuracy due to calculation errors



Thought Process

What are possible instrumental or procedural errors?



Thought Process

Procedural errors.

[Total: 20]

